

6400 Series Horizontal Loading Valves

The OPW Horizontal Loading Valve has a long-standing reputation for reliability and quality throughout the petroleum industry. This reputation is backed by more than five decades of successful service in the most difficult environments.

Benefits

- **Spring-Loaded "Deadman" Operation** - Valve must be manually held in open position and automatically closes upon release of handle.
- **Minimize Line Shock** - Variable closure rate allows operator to fine tune closure rate and prevent shock.
- **Easy Maintenance** - Unique stuffing box design makes disassembly quick and easy.
- **No Air Traps** - Air cannot become trapped in the valve, minimizing the risk of product release after closure.
- **No Special Tools Required.**
- **Superior Shaft Sealing**- Dual O-rings provide redundant sealing in this critical area.



A wide range of other valves, including ball, butterfly and plug types can also be incorporated into your OPW Loading Arms. Consult your OPW representative for more information.

Selection Guide

Horizontal Loading Valve

6 4 2 9 V - 0 3 0 2

B = Buna-N
V = Fluorocarbon
EP = EPDM

01 = Buna-N
02 = Fluorocarbon
04 = EPDM

03 = 3"
04 = 4"

Seal Replacement Kits

6401RK-0301

6401RK= for 6429B and 6549B Loading Valves

6402RK= for 6429V and 6549V Loading Valves

Availability of styles, sizes, and materials may vary depending upon configuration. Consult OPW Customer Service regarding your exact requirements.

**Includes main disc seal, secondary seal, PTFE seal rings, shaft seals, cap gaskets, and seals.*

6 4 0 1 R K - 0 3 0 1 *

6401RK = Buna-N

6402RK = Fluorocarbon

03 = 3"

04 = 4"

01 = Buna-N

02 = Fluorocarbon

04 = EPDM

Index

6400 Series Horizontal Loading Valves Overview	1
Technical Information	2-4
Installation	5
Maintenance	6-11

Technical Information

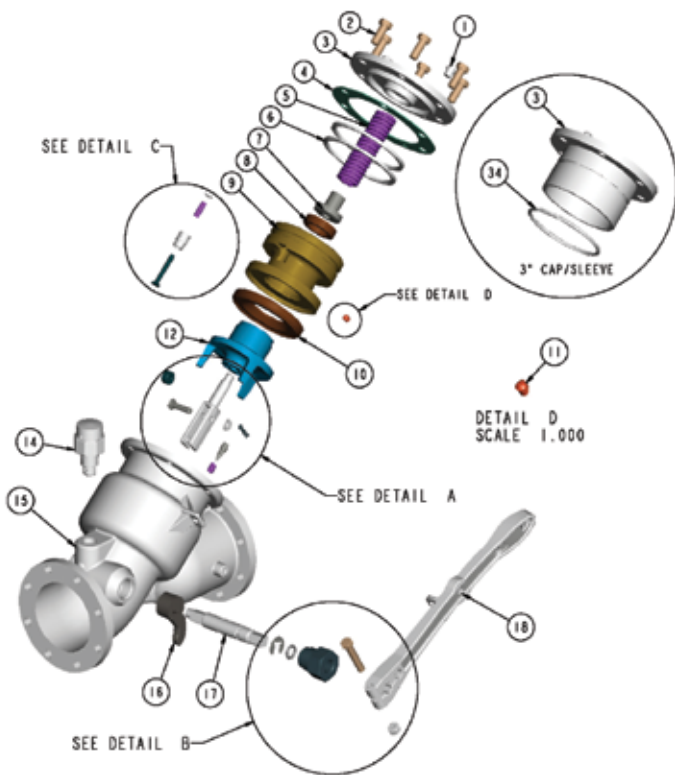

BEFORE May 2010

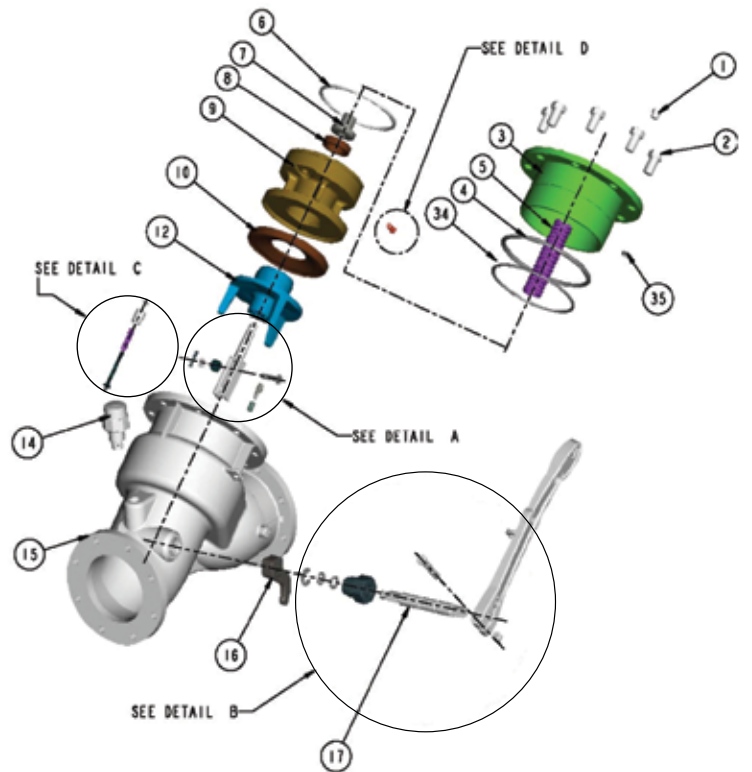

AFTER May 2010

See part numbers on page 4

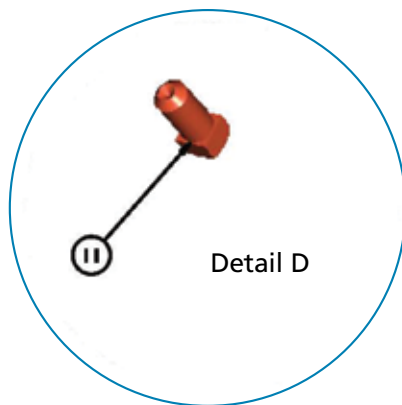
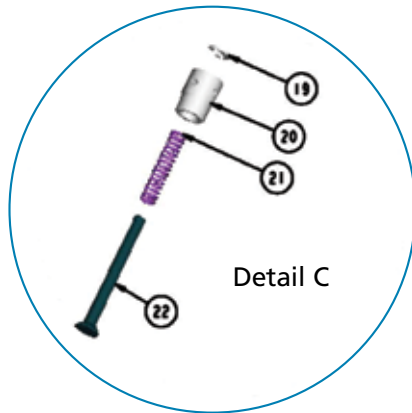
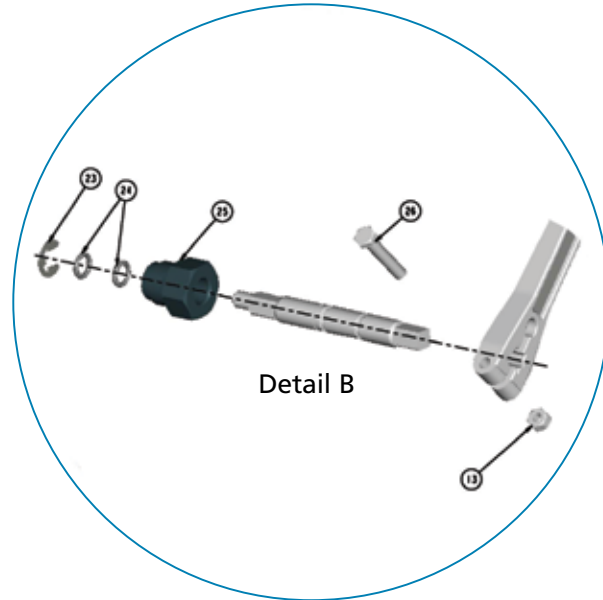
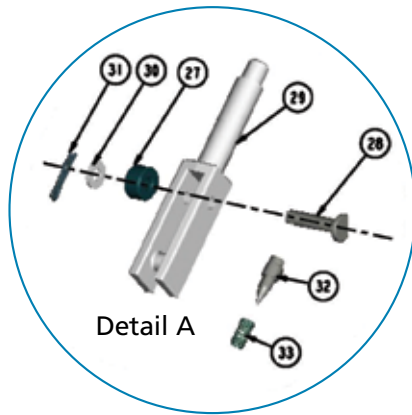

Design Parameters

Design Standard	ASME B31.3
Max. Design Temperature	250° F (121°C)*
Min. Design Temperature	See Seal Material Charts
Max. Working Pressure	5 bar (75 PSI)

* Max. design with EP Seals = 225°F (107°C)

Materials

Body	Aluminum (ASTM B26 A356-T6 - ALUM)
Shaft	AISI 416 SST
Seal Cylinder	ASTM B26 A356-T6 - ALUM
Carrier	ASTM A351 CF8M - SST
Seals	See Seal Chart

Seal Materials	Temp Rating
Fluorocarbon	-20°F - 400°F (-29°C - 204° C)
Buna-N	-20°F - 212°F (-29°C - 100° C)
EPDM	-50°F - 250°F (-46°C - 121° C)

3" & 4" Upgrade Kit Now Available – For previous generation 3" and 4" loading valves. These kits include all components to update to current design:

3" Upgrade Kit: 6402UK-0302

4" Upgrade Kit: 6402UK-0402

Technical Information

Description		6429V-0302	3" – 6429V-0302 AFTER May 2010	6429V-0402	4" – 6429V-0402 AFTER May 2010
1	PIPE PLUG	H-30706-M		H-30706-M	
2	BOLT, CAP	H-30137-M (6)		H-03520-M (8)	
3	CAP / SLEEVE	C-20661-A		C-20158-A	C-21209-A
4	O-RING, CAP/SLEEVE ▲	H-071175-M (GASKET)	H-30217-M (O-RING)	C-02261-M (GASKET)	H-32223-M (O-RING)
5	SPRING, POPPET	H-07278-M		H-07357-M	
6	WEAR RING ▲	H-31421-RA		H-30601-M(2)	H-32260-M
7	POPPET, SECONDARY	H-30603-RA		H-30603-RA	
8	SEAL ▲	H-30586-M		H-30586-M	
9	POPPET	C-20156-A		D-20083-A	C-21342-A
10	MAIN DISC ▲	H-30583-M		H-30589-M	
11	SET SCREW	H-30602-M		H-30602-M	
12	GUIDE, POPPET	C-20155-AH		C-20162-AH	
13	NUT	H-30174-M		H-30174-M	
14	VACUUM BREAKER	4765A-0150		4765A-0150	
15	BODY	E-20034-A		E-20036-A	
16	CARRIER	H-07182-M		H-07375-M	
17	SHAFT	H-07184-RE		H-07377-RE	
18	LEVER	C-02244-DI		C-02244-DI	
19	RETAINING RING	H-20627-M		H-20627-M	
20	SPRING, CHECK VALVE	H-03090-M		H-03092-M	
21	BODY, CHECK VALVE	H-30595-RA		H-30595-RA	
22	STEM, CHECK VALVE	H-30578-RA		H-30645-RA	
23	RETAINING RING, STEM ▲	H-30433-M		H-30433-M	
24	O-RING, STUFFINGBOX ▲	H-01094-M	H-01094-M (2)	H-01094-M	H-01094-M (2)
25	STUFFINGBOX	H-07180-RAH		H-07180-RAH	
26	BOLT, LEVER	H-05458-M		H-05458-M	
27	ROLLER	H-06234-RE		H-06234-RE	
28	CLEVIS PIN, STEM	H-03714-M		H-03714-M	
29	STEM	H-07178-EW		H-07378-EW	
30	WASHER	H-03715-M		H-03715-M	
31	COTTER PIN	H-30101-M		H-30101-M	
32	ADJUSTING SCREW	H-30591-RE		H-30591-RE	
33	SPRING, ADJ SCREW	H-31000-M		H-31000-M	
34	O-RING, SLEEVE ▲	H-30594-M	H-01090-M		H-32224-M
35	O-RING, CAP- ADJUSTING SCREW ▲		H-51356-M		H-51356-M

▲ = Items Included In Repair Kits

Note: Above part numbers reflect standard Loading Valve with fluorocarbon seals. Consult factory for alternate seal part numbers.

Loading Valve Installation



- Secure whatever device loading valve will be mounted to (e.g., Loading Arm, Piping)
- Align bolt holes so that nothing will get in the way of the operating handle once installed
- Bring flanges together sandwiching the gasket in between

Seal Replacement



Read & Understand These Instructions Before Starting Installation

- Loading Valve to be used for its designated purpose only
- Local regulations for (un)loading must be followed at all times
- Product flow may result in static electricity; grounding of equipment is required
- OPW instructions must be followed for installation at all times
- Make sure to use adequate personal protection at all times during operation

Warning

- Secure piping before attempting to remove loading valve
- Release all pressure from the system before attempting any seal replacement

For replacement of all seals (excluding gaskets between mounting flanges)

- Shut down and drain system and relieve all pressure
- Be sure to place a lock out tag on any equipment connected to the loading valve
- Disassemble valve, (see page 5 for detailed disassembly instructions)
- Clean and inspect all sealing surfaces after removing seals
- Install new seals and re-assemble valve, (see page 7 for detailed rebuild instructions)

If flange gaskets need to be replaced

- Shut down and drain system to relieve all pressure
- Be sure to place a lock out tag on any equipment connected to system
- Dismantle loading valve and discard gaskets
- Clean and inspect flange surfaces
- Reinstall new gaskets and reinstall (see section 2 for details)

Closing Rate Adjustment

Caution: Remove pressure from line before starting adjustment.

Step 1: Remove adjusting screw plug.

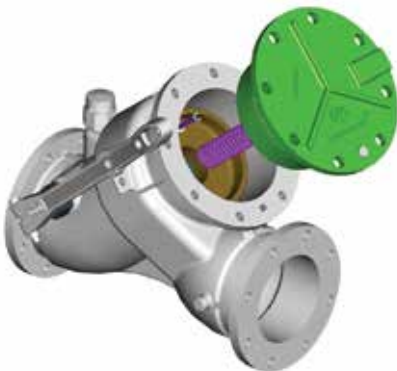

Step 2: a. To slow closure rate (reduce line shock): Turn adjustment screw clockwise in 1/4 turn increments.

b. To speed up closure rate: Turn adjustment screw counterclockwise in 1/4 turn increments.

Step 3: Replace adjustment screw plug and test.

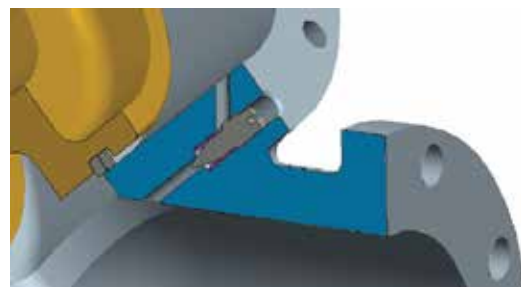

Seal Replacement Instructions

Step 1:

- Remove Valve from Loading Arm following precautions on previous page.

Step 2:

- Unthread and remove bolts securing cap/sleeve.



CAUTION

Caution: Cap/sleeve bolts are under pressure from internal spring.

Step 3:

- Remove the spring and cap/sleeve.

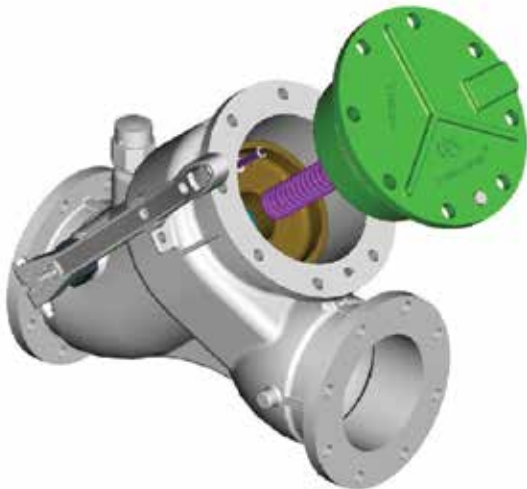

Step 4:

- Rotate handle up 90 degrees to allow extraction of the poppet assembly.



Step 5:

- Loosen nut on handle and pry it off of shaft.



Seal Replacement Instructions

Step 6:

- Unthread shaft stuff box and remove it from valve body.
- Secure the carrier inside the valve.



Step 9:

- Unthread tail from seal cylinder. Secure seal.

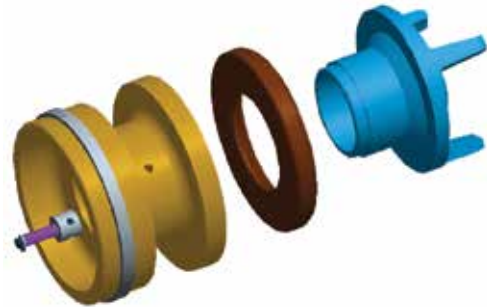

Step 10:

- Remove the wear ring from the poppet.



Step 7:

- Remove the poppet stem assembly and seal by loosening the threaded nut securing it.

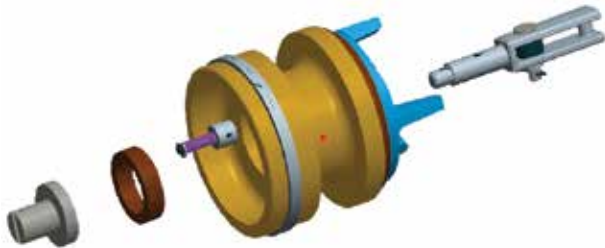

Step 11:

- Pull the stuffing box off of the shaft.



Step 8:

- Remove set screw from side of seal cylinder.

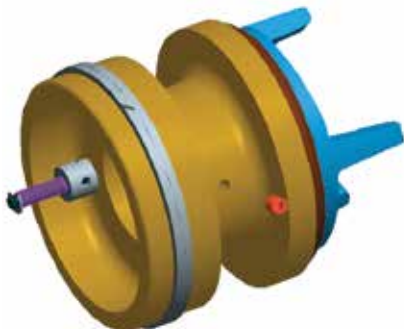

Step 12:

- Carefully remove O-rings. **Note:** It is only necessary to remove the O-rings from the shaft, not the e-clip.



Detailed Rebuild

Step 1:

- Carefully apply light oil to (2) O-rings and roll over shaft and into grooves.



Step 2:

- Slide stuff box onto shaft up to e-clip.



Step 3:

- Form the wear ring and seat into groove.



Step 4:

- Press main disc into base of poppet and thread poppet guide behind it.

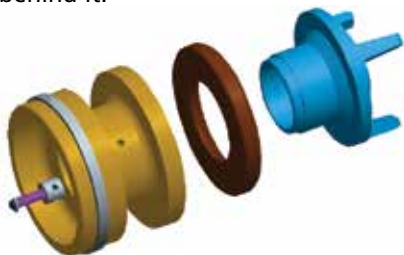

Step 5:

- Continue screwing guide into poppet until hand tight and seal is compressed slightly.

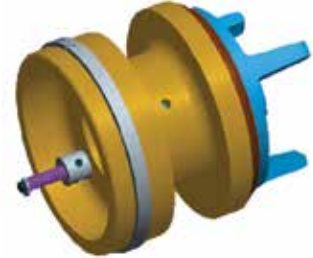

Step 6:

- Thread set-screw into poppet and tighten.

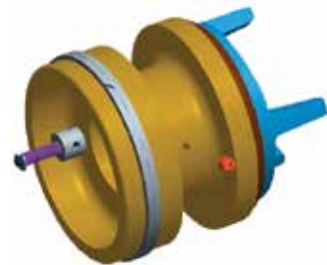

Step 7:

- Press seal into poppet guide.
- Slide poppet stem assembly through poppet guide and seal.
- From the opposite side, thread the nut onto the poppet stem.

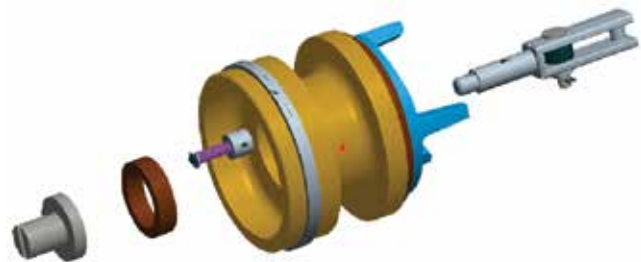

Detailed Rebuild

Step 7 (continued):

- Finish seal cylinder assembly

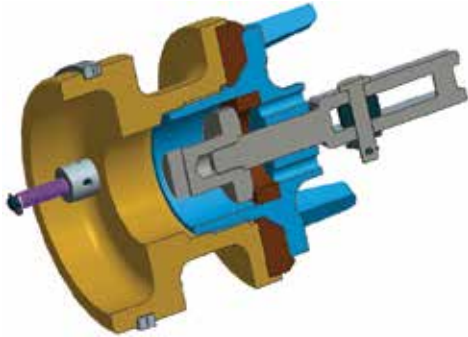

Step 8:

- Hold carrier inside valve body, and align shaft assembly as shown.



Slide carrier onto shaft while threading stuffing box into body.

Torque to 50 ft-lbs.



Step 9:

- With the shaft turned so that the carrier is in the downward position as shown, install the handle assembly so that the handle is in line with the body as shown.

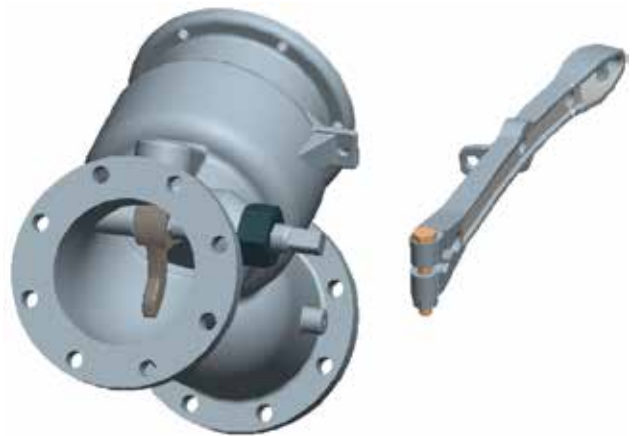

- Tighten down handle nut.



Step 10:

- Rotate handle backwards, approximately 90 degrees.

Note: Arm needs to be far enough back so that the carrier is not in the center of the valve body.



Detailed Rebuild

Step 11:

- Align poppet assembly as shown with the relief valve on the seal cylinder in the top position (see below for better visual description).
- Feed poppet assembly into body.



- Once seal poppet stem has passed the carrier, rotate the handle down to capture poppet assembly.

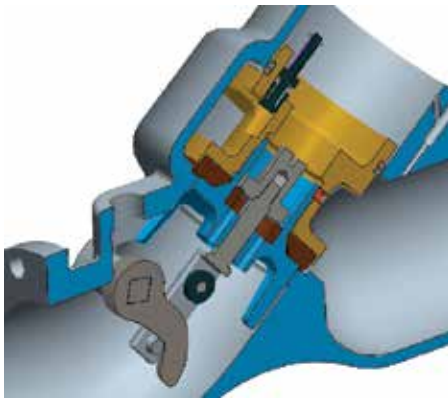

- When the handle is in this position the carrier should be locking the poppet assembly inside the valve.



Step 12:

- Align spring and threaded adjustment screw with hole in body.



- Thread adjustment screw into body after spring and tighten with flat head screw driver

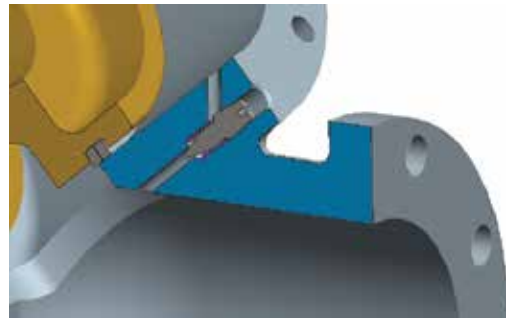

Detailed Rebuild

Step 13:

- Install the cap/sleeve O-ring and the adjustment screw O-ring.
- Align seal cylinder spring with the cap/sleeve.
- While compressing the poppet spring, initiate ALL bolts and take them to finger tight.
- Torque the cap bolts in a criss-cross pattern to 20 ft-lbs.

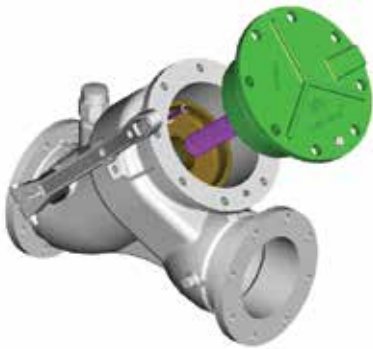

- Apply thread sealer and install adjusting screw plug.
- Fasten securely.



Step 14:

- Apply thread sealer and thread the vacuum breaker as shown into the body.
- Fasten securely.



Assembly Complete

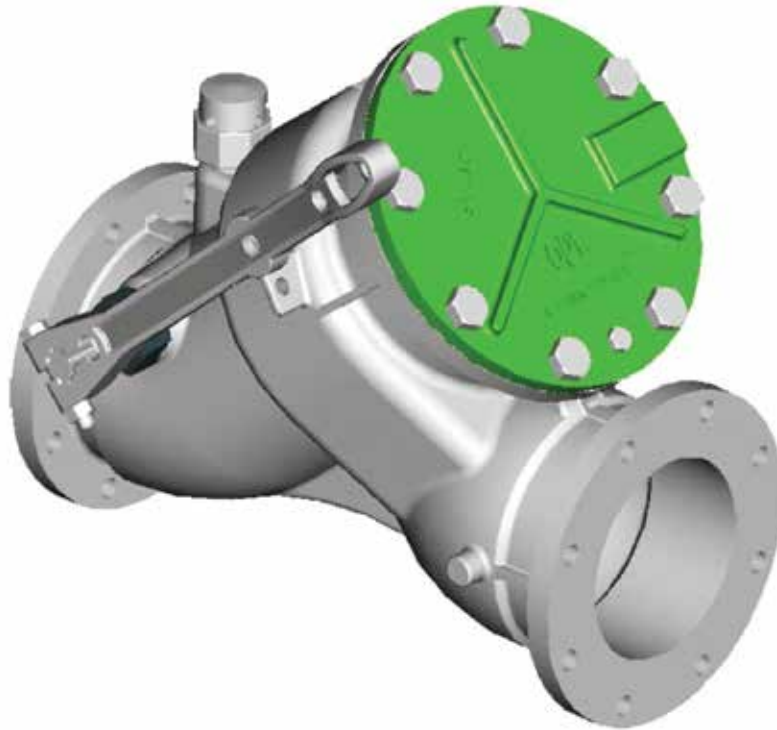

WARNING

Failure to follow these warnings could result in serious personal injury, property damage or product failure.

- 1) Do not attempt any maintenance service while the equipment is in operation. System pressure must be relieved and the product drained before attempting any service on the unit. The line must be locked out while service is in progress. Proper thermal relief must be provided at all times while equipment is in service.
- 2) OPW products do not eliminate possible exposure to hazardous substances. The conditions of handling and use are beyond our control, and we make no guarantee and assume no liability for damages or injuries related to the use of our products. Follow the safety precautions outlined in the Material Safety Data Sheets for the material being used. It is the responsibility of the user to comply with all federal, state and local regulations. Always employ proper safety precautions and handling techniques.
- 3) Proper seal and wetted material part selection is critical for safe operation. To assure maximum life for the service intended, use only those materials compatible with the fluids being handled. Please note material being supplied and make certain that it is suited for the intended service.

IMPORTANT: OPW products should be used in compliance with applicable federal, state, provincial, and local laws and regulations. Product selection should be based on physical specifications and limitations and compatibility with the environment and materials to be handled. OPW MAKES NO WARRANTY OF FITNESS FOR A PARTICULAR USE. All illustrations and specifications in this literature are based on the latest product information available at the time of publication. OPW reserves the right to make changes at any time in prices, materials, specifications and models and to discontinue models without notice or obligation.